



National
Defence

Défense
nationale



CANADIAN
ARMED FORCES

DÉMYSTIFIER LA PROPRIÉTÉ INTELLECTUELLE (PI)

Atelier national de l'institut canadien
d'approvisionnement et de gestion du matériel

Le 5 juin 2019

AnhThu Vu

Canada



La Couronne

utilise/crée

la PI tous les jours

ACTIF INTANGIBLE = L'OR NOUVEAU



GESTION





4 PARTIES

PARTIE 1

QU'EST-CE QUE LA PI?

Les **actifs**
intangibles sont
la création de
l'esprit



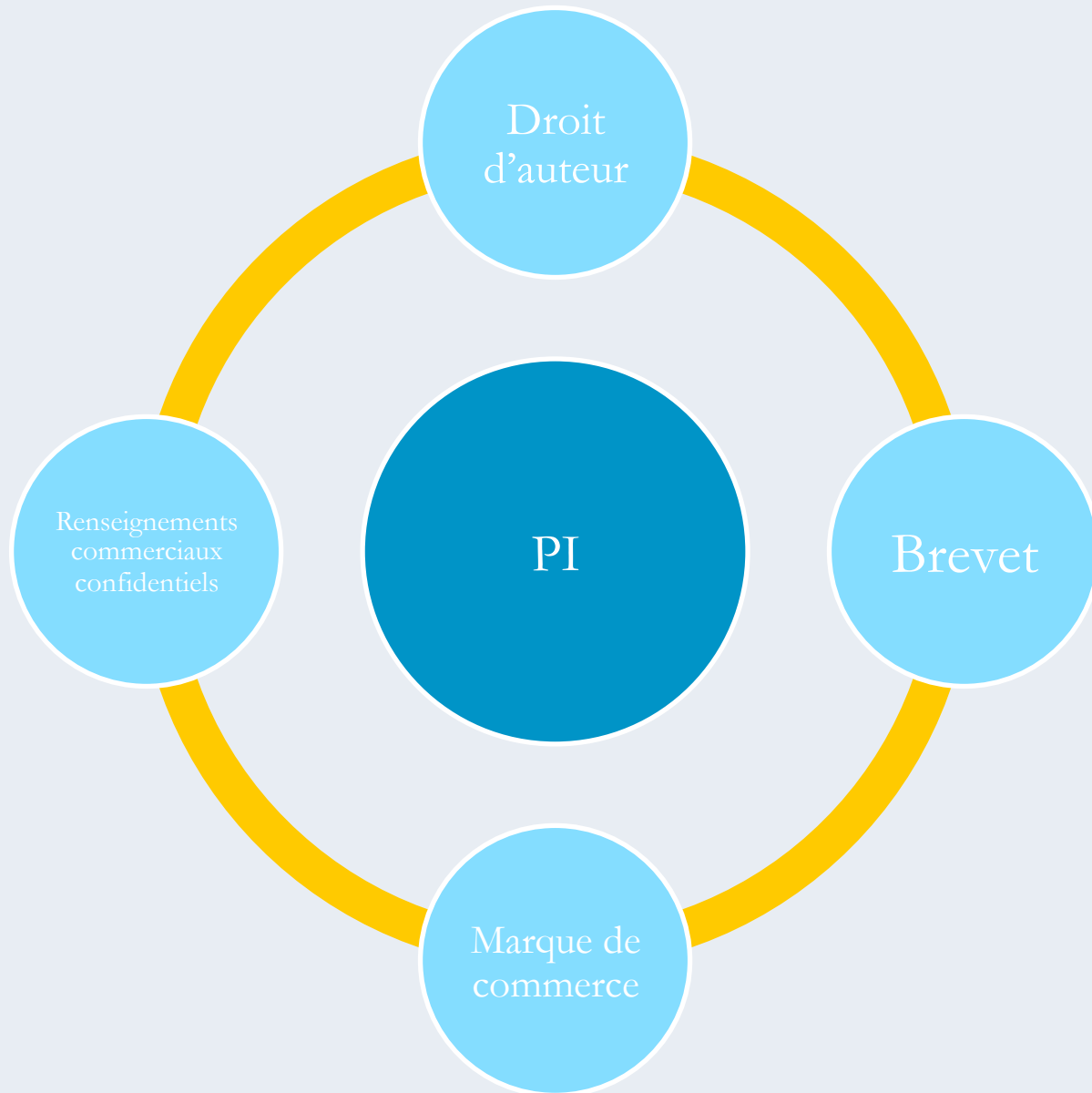



Œuvres musicales



Œuvres dramatiques

Le droit d'auteur

protège
l'expression
de l' Œuvre

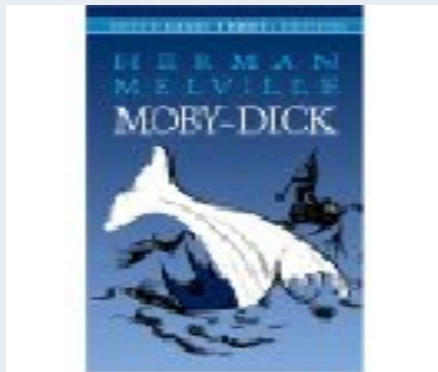

Œuvres littéraires



Œuvres artistiques

Le brevet protège une invention

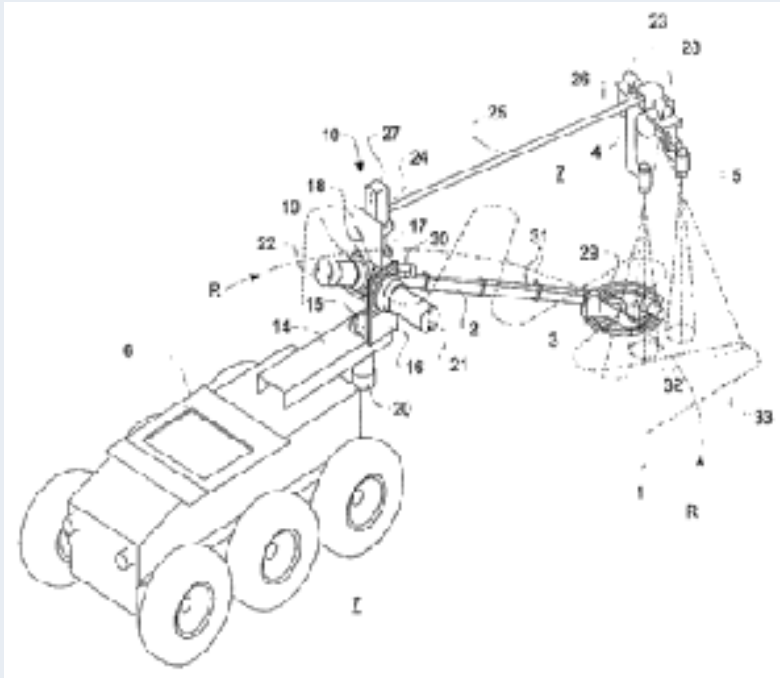

Brevet CA 2,339,924

« Scanneur robotisé articulé pour la détection de mine »

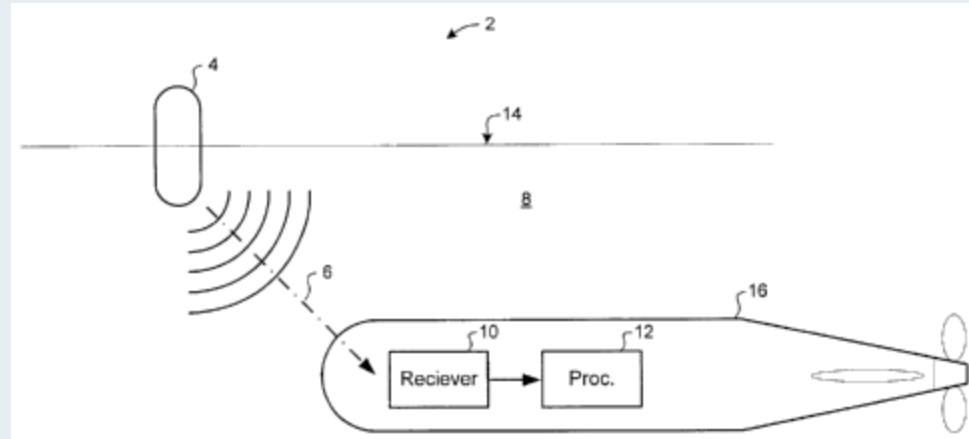

CA 2,770,247

« Système et méthode de ralliement pour un véhicule sous-marin autonome »

Une marque de commerce protège un mot, symbole, dessin ou son

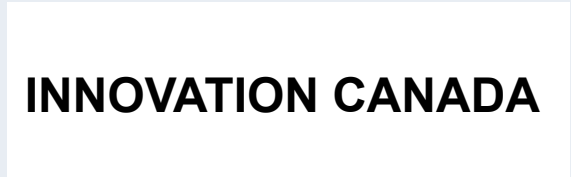
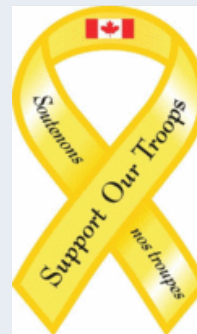
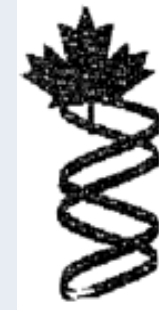

La désignation de
renseignement à titre
de renseignements
commerciaux
confidentiels

protège la

confidentialité de
l'information



PARTIE 2

ET ALORS?



La Couronne

utilise/crée

la PI tous les jours



Élaboration de politiques





Modelo MIC-200 da marca M...
câmera modelo CAM-100...
Marte

CE

WPT 2000 2000
WPT 2000 2000









A photograph of a submarine docked at a pier. The submarine is dark grey and has a conning tower with a flag on top. Several crew members are visible on the deck. The text 'PAS PRÊT au niveau de PI!' is overlaid in red with a white outline. The background shows a body of water and a distant shoreline with buildings.

PAS PRÊT au
niveau de **PI!**

An illustration of two hands shaking in a firm grip. The hands are rendered in a stylized, cartoonish manner with orange skin and black outlines. The hands are wearing silver metal handcuffs, which are connected by a chain of three links. The background is white. The text 'MEILLEUR PRIX?' is overlaid in the center of the image in a blue, serif font with a drop shadow effect.

MEILLEUR PRIX?

A close-up photograph of a person's hands holding an open, empty brown leather wallet. The wallet is made of textured leather and has a dark interior lining. The hands are positioned to show the inside of the wallet, which is completely devoid of any money or cards. The background is a soft, out-of-focus grey. Overlaid on the center of the image is the text "COÛTS EXORBITANTS!" in a bold, blue, serif font with a white outline.

COÛTS EXORBITANTS!

PARTIE 3

GESTION de la PI

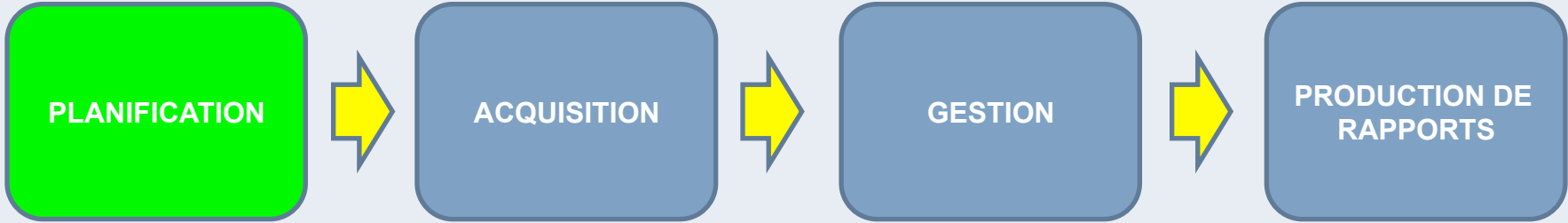

La planification comprend **deux** volets



Identification



Connaissances

Apprentissage

Formation



Politique sur les droits de PI et guide

Cours C282 du EFPC

MDN – Cours élémentaire

MDN – Cours pour les officiers d'approvisionnement

Organisations et bureaux de la PI :

- Office de la PI du Canada
- Organisation mondiale de la PI





Ancienne méthode

Nouvelle méthode

**Mise à
niveau**

**Mise à
jour**

Modification

Réparation

Conception

Reproduction

Traduction

Création

Invention



De quoi avons-nous besoin?

La définition des besoins
comprend **deux** volets



Quels droits de PI? À quelles fins?

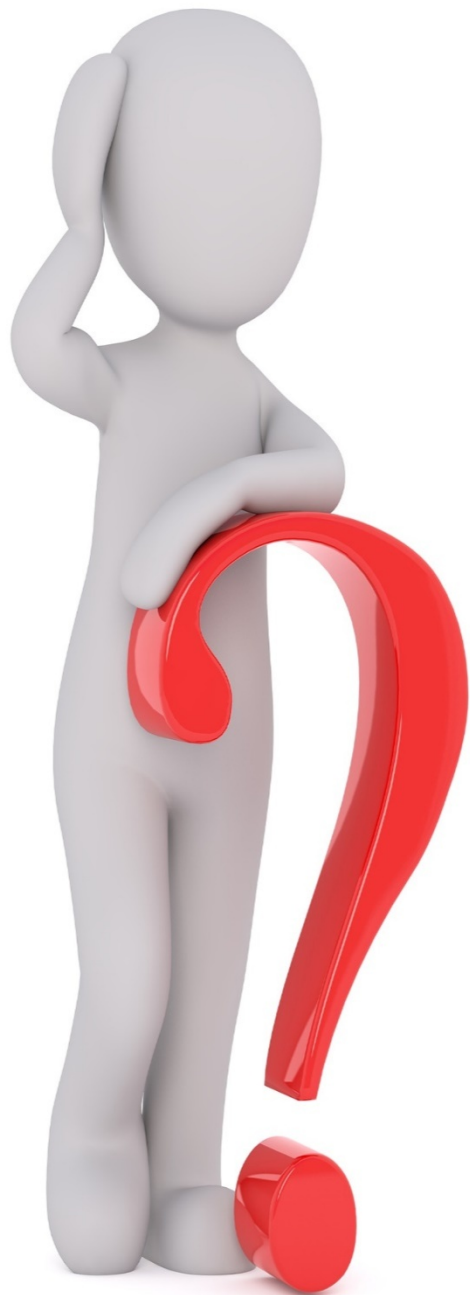

Licence

ou

Droits de propriété

Licence = droits **limités**

limité \neq insuffisant

Droits de propriété = Droits complets

A weathered wooden signpost stands in the center of the frame. The signpost is made of two vertical wooden posts. The top post is shorter and has two small dark spots. The bottom post is taller and has two large, dark, circular knots. A horizontal wooden arrow is attached to the top post, pointing to the right. The arrow has a notched left end and a pointed right end. The text "Politique sur les droits de la PI" is written in yellow on the arrow. The background is a vast, hazy landscape of snow-covered mountains under a grey, overcast sky.

Politique sur les
droits de la PI



Accentuer la croissance
économique

L'entrepreneur détient les droits
de la PI originale

L'État détient les droits en cas
d'exception

PI originale

et

PI contextuelle

La PI originale

est

développée dans le cadre du contrat

La PI contextuelle

est

tous les autres éléments

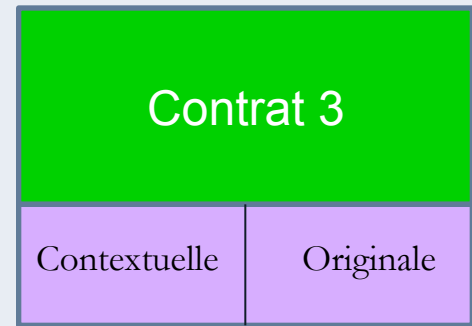
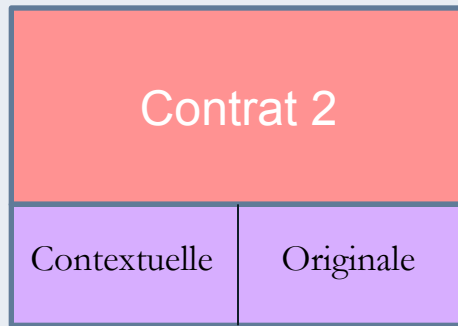
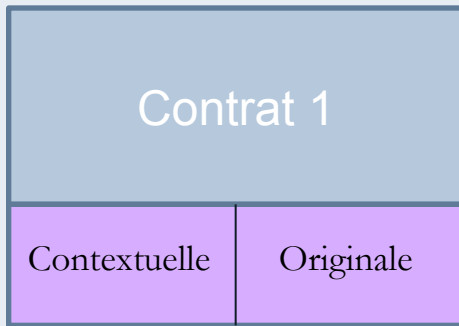

Sitzecke



Cinq exceptions

```
a.fn.scrollTop=d,this},a(window).on("click.bs.tab",function(){var b=a(
),+function(a){"use strict";function b(b){return this.each(function(){var
be(b)}))var c=function(b){this.element=a(b)};c.VERSION="3.3.7",c.TRANSITION_DURATION=150,c.pro
opdown="menu"),d=b.data("target");if(d||(d=b.attr("href"),d=d&&.replace(/.*(?=#[\^s]*$)/,"")),!
st a"),f=a.Event("hide.bs.tab",{relatedTarget:b[0]}),g=a.Event("show.bs.tab",{relatedTarget:e[0]
faultPrevented()){var h=a(d);this.activate(b.closest("li"),c),this.activate(h,h.parent(),functio
rigger({type:"shown.bs.tab",relatedTarget:e[0]}))}}},c.prototype.activate=function(b,d,e){func
u > .active").removeClass("active").end().find("[data-toggle="tab"]').attr("aria-expanded",!1),
ia-expanded",!0),h?(b[0].offsetWidth,b.addClass("in")):b.removeClass("fade"),b.parent(".dropdo
().find("[data-toggle="tab"]').attr("aria-expanded",!0),e&&e())var g=d.find("> .active"),h=e&&
e")||!d.find("> .fade").length);g.length&&h?g.one("bsTransitionEnd",f).emulateTransitionEnd
;var d=a.fn.tab;a.fn.tab=b,a.fn.tab.Constructor=c,a.fn.tab.noConflict=function(){return a.fn.t
"show");a(document).on("click.bs.tab.data-api",[data-toggle="tab"],e).on("click.bs.tab.data
se strict";function b(b){return this.each(function(){var d=a(this),e=d.data("bs.affix"),f="ob
typeof b&&e[b]}))var c=function(b,d){this.options=a.extend({},c.DEFAULTS,d),this.$target=a
,a.proxy(this.checkPosition,this)).on("click.bs.affix.data-api",a.proxy(this.checkPositionW
null,this.pinnedOffset=null,this.checkPosition());c.VERSION="3.3.7",c.RESET="affix affix-top
State=function(a,b,c,d){var e=this.$target.scrollTop(),f=this.$element.offset(),g=this.$targ
"bottom"==this.affixed)return null=c?!(+this.unpin<=f.top)&&"bottom":!(e+g<=a-d)&&"bottom"
!c&&e<=c?"top":null=d&&i+j>a-d&&"bottom"},c.prototype.getPinnedOffset=function(){if(this
.RESET).addClass("affix");var a=this.$target.scrollTop(),b=this.$element.offset();return
withEventLoop=function(){setTimeout(a.proxy(this.checkPosition,this),1))
ent.height(),d=this.options.offset,e=d.top,f=d.bott
peof e&&(e=d.top(this.$element))\ "
ent.css("top","")
```

Sécurité nationale



Loi

Obligation antérieure





Diffusion publique

Ajout à une PI contextuelle de l'État

Sous-système

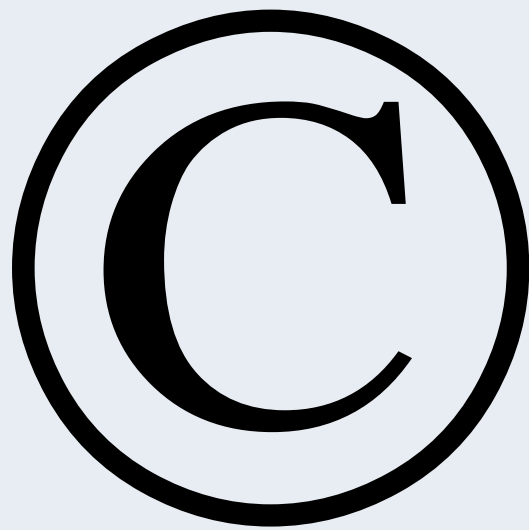



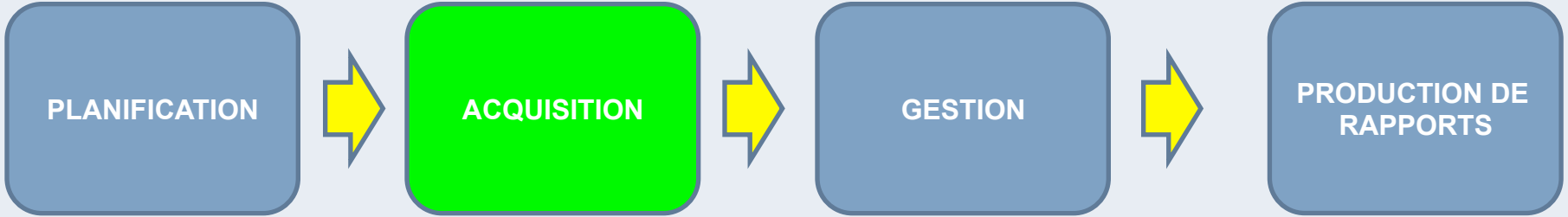

Trois types de clauses et conditions
uniformisées d'achat (CCUA)



Conditions générales

Conditions générales
supplémentaires

Clauses uniformisées
d'achat

Conditions générales

2010B

2030

2035

2040



Conditions générales supplémentaires

4006/4007

Les plus **exhaustives**

Clauses uniformisées d'achat

Clauses **K**

Situations **particulières**



Annexe 4.2

(Guide des approvisionnements)

Organigramme du MDN

(document distribué)

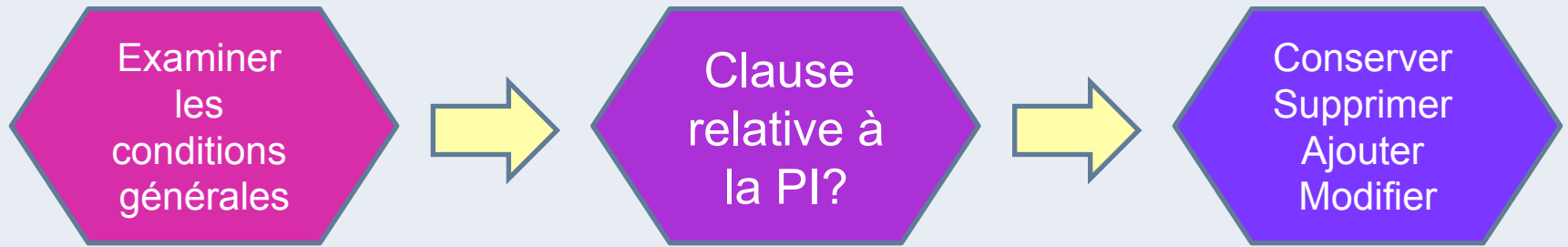

4006 et 4007

Clauses K

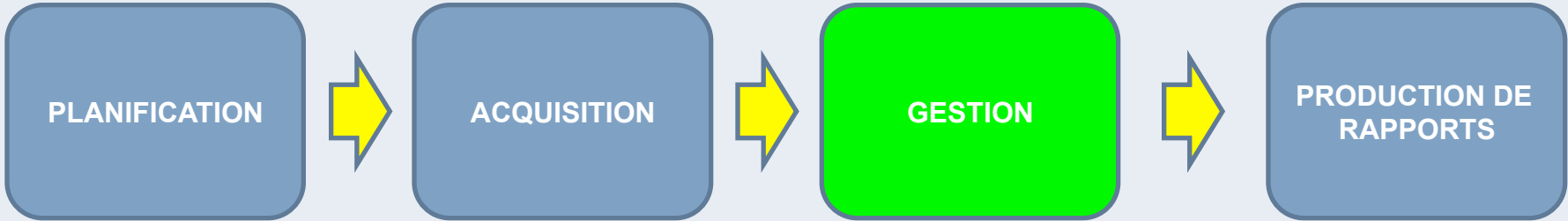

Valider les éléments livrables

Conserver les documents si des

clauses survivent

à l'expiration du contrat

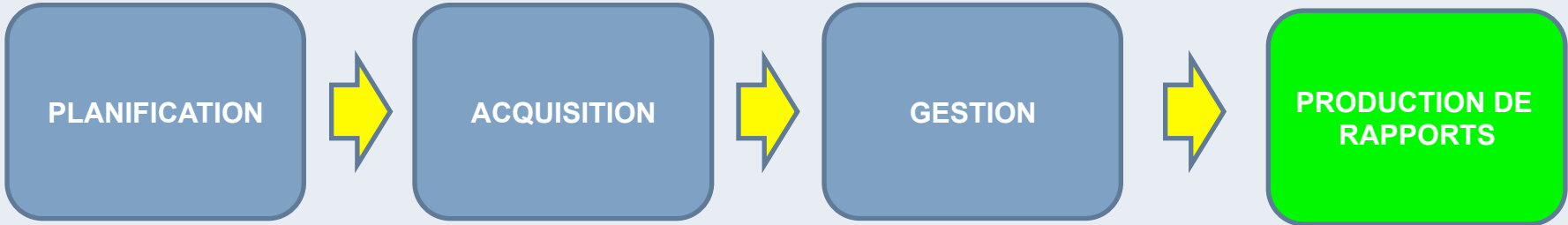

droits de propriété

Commercialisation

PARTIE 4

GUIDE de la PI du SCT

GESTION DU CYCLE DE VIE DU MATÉRIEL

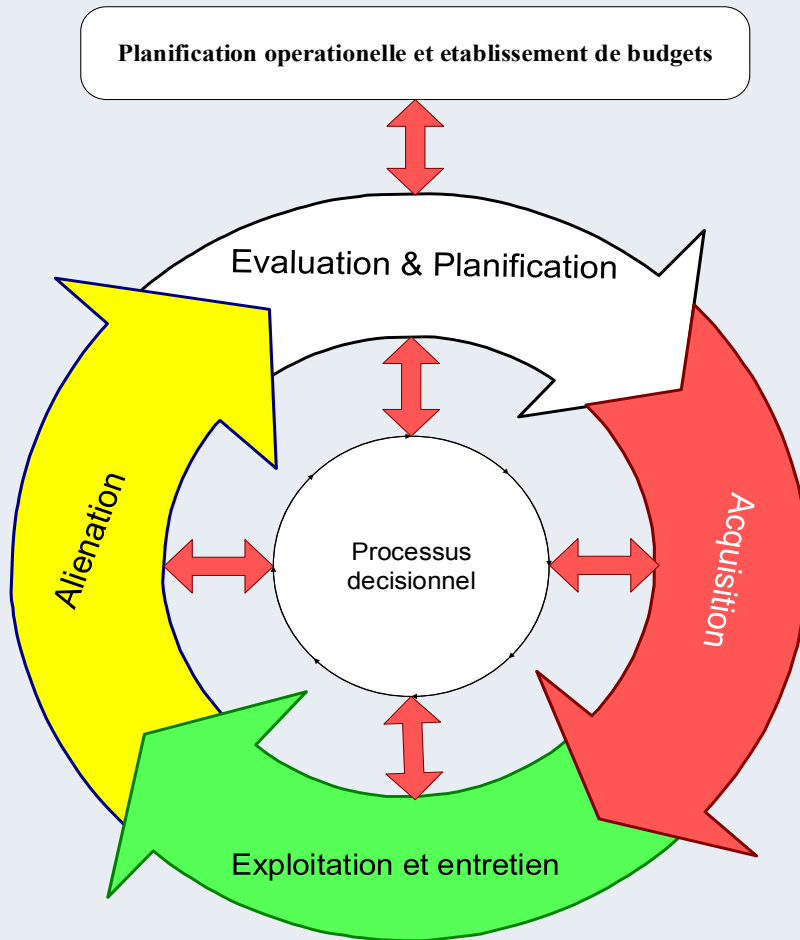

GESTION DU CYCLE DE VIE DE LA PI

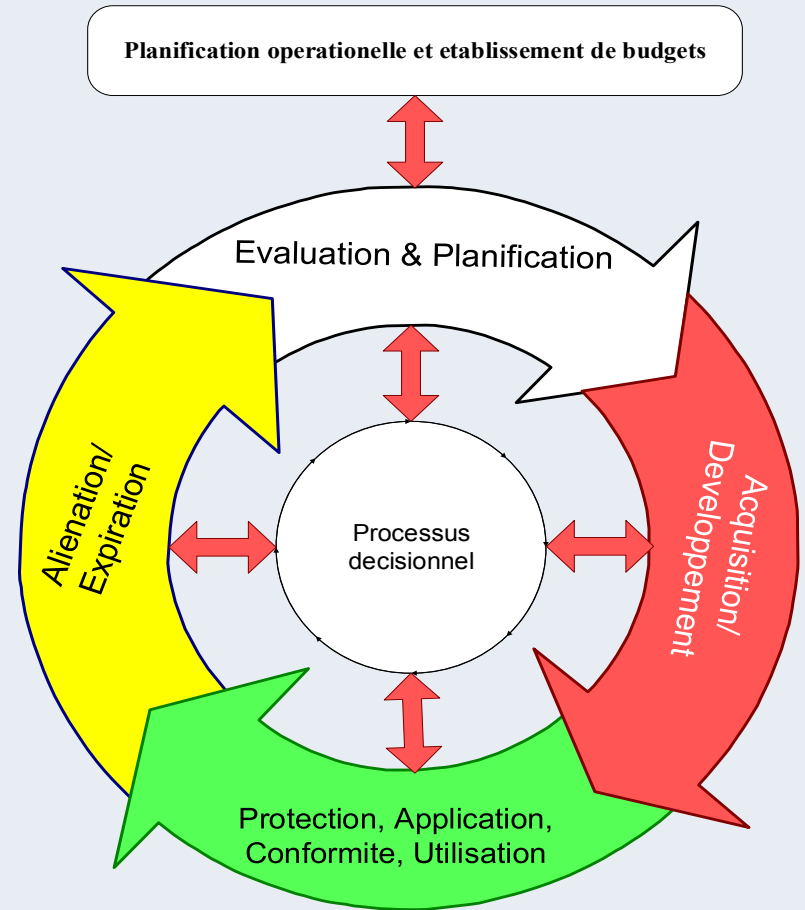

Deux scénarios :

- Droits de propriété de la PI détenus par l'État
- Licence de PI détenue par l'État



MERCI!

AnhThu Vu

Gestionnaire de la propriété intellectuelle, MDN

anhthu.vu@forces.gc.ca

819-939-8672

Questions et réponses

QUESTION 1

Est-ce qu'une PI est créée lorsqu'un produit en vente libre est acheté?

RÉPONSE 1

Non

QUESTION 2

Le Couronne souhaite généralement que les fournisseurs conservent la PI créée dans le cadre d'un marché d'approvisionnement de l'État
(Vrai/Faux)

RÉPONSE 2

Vrai

QUESTION 3 : La PI est-elle pertinente?

Situation	Oui/Non
Contrat de recherche et développement	
Un entrepreneur réalise une étude sur l'habitat du poisson et fournit un rapport	
Un logo est créé dans le cadre d'un contrat	
Contrat visant la mise à jour de matériel didactique de l'État	
Contrat pour l'achat d'articles de papeterie	

QUESTION 4 : Originale ou contextuelle?

Situation	Originale/ Contextuelle
Matériel nouvellement créé	
Extraits de travaux protégés par des droits d'auteur qui existaient avant l'attribution du contrat	
Codes source mis à jour pour un logiciel de l'État	
Dessins techniques utilisés dans le cadre de contrats précédents	